

A Force of Nature

slate effect
RI COLLECTION

L
I
F
E

I
N

S
T
O
N
E

MODELLED BY TIME

Raging, serene, gurgling quietly and flowing rapidly again, water is a primordial element that conveys energy and creates harmony. A dialogue is created between the natural universe and the interior dimension, in a continuous influence on environments and perceptions. The materials are vibrant, drawing light and creating a delicate alternation between chiaroscuro and reflections, enlivening spaces with a renewed ancestral strength.

Embrace the beautiful dichotomy of nature with this collection. Textured and structured, yet smooth and delicate – just like water's effect on stone.

The essence of the beauty of natural stone and marble in the surfaces, where each detail is a tribute to the unique characteristics of these materials. Through careful observation and synthesis of natural phenomena, graphic signs have been created that infuse depth and dynamism into every texture.

The collection presents a natural palette of shading, with significant graphic and chromatic transitions between one tile and the next, whilst still maintaining an overall balance of the installed surface.

Beauty inspired by nature at its finest.

the
collection

-slate effect-



white RI

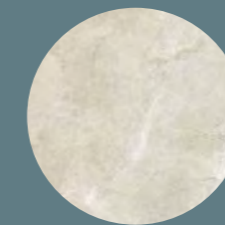

beige RI

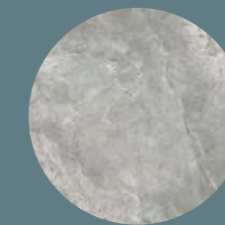

grey RI

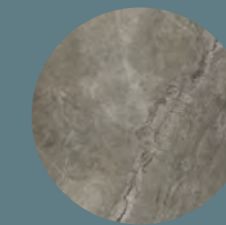

natural RI

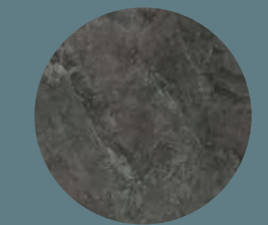

graphite RI

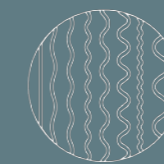

FINISHES

natural R10 (nat)
honed (hn)
polished (pol)
grip R11 (gr)



THICKNESSES

6 mm
9 mm
20 mm

▣ WHITE P.4

▣ BEIGE P.10

▣ GREY P.14

▣ NATURAL P.21

▣ GRAPHITE P.27

▣ DÉCOR OPTIONS P.32

▣ TECHNICAL CHARACTERISTICS P.35



WHITE



WHITE



WHITE
1200 X 1200 hn



WHITE
900 X 900 gr (2mm)

GRIP FINISH:

The raw beauty of stone in its purest form. The absence of water creates a wonderfully rough surface, perfect for outdoor settings. Its strongly textured structure adds an elemental touch to any space, bringing nature's timeless allure to life.



WHITE
inside floor 1200 X 1200 hn
outdoor floor 900 x 900 gr (20mm)

Chevron, with its classic shape emphasised by the glossy finish, translates the refined essence of the material with the elegant fishbone application that is back in the spotlight in certain contexts, especially commercial premises.



WHITE
chevron 260 x 325 pol



WHITE - cool contemporary lightness

WHITE
inside floor 1200 X 1200 hn
outdoor floor 900 x 900 gr (20mm)

nature's artwork



9 mm

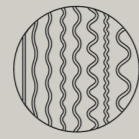

natural R10 (nat)
honed (hn)
polished (pol)
grip R11 (gr)

SIZES & finishes

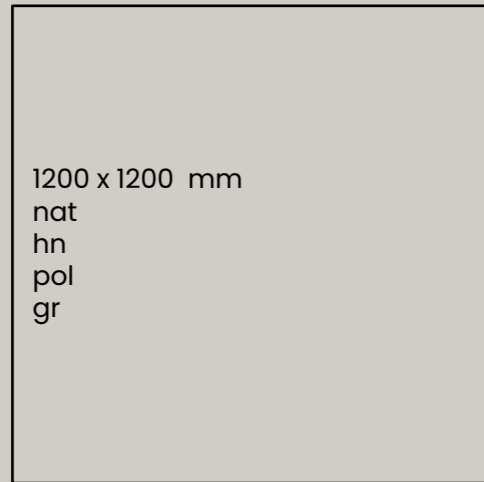

1200 x 1200 mm
nat
hn
pol
gr

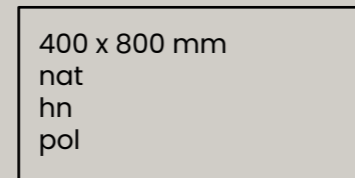

400 x 800 mm
nat
hn
pol

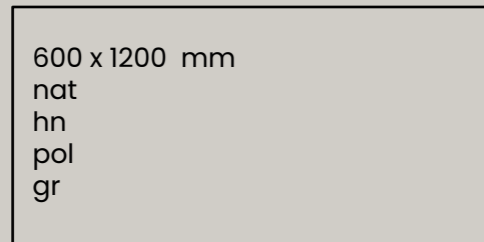

600 x 1200 mm
nat
hn
pol
gr

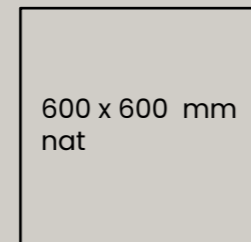

600 x 600 mm
nat

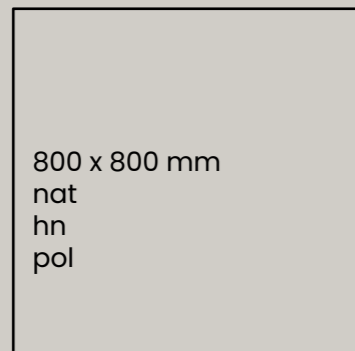

800 x 800 mm
nat
hn
pol

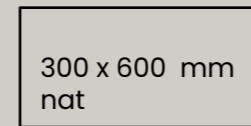

300 x 600 mm
nat



20 mm



grip R11 (gr)



6 mm

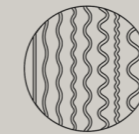

natural (nat)

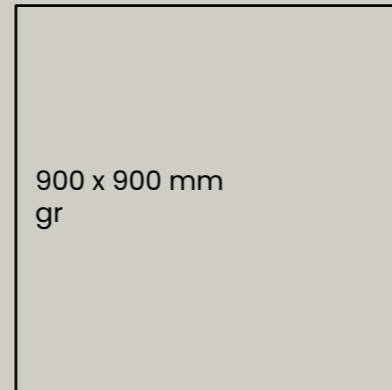

900 x 900 mm
gr

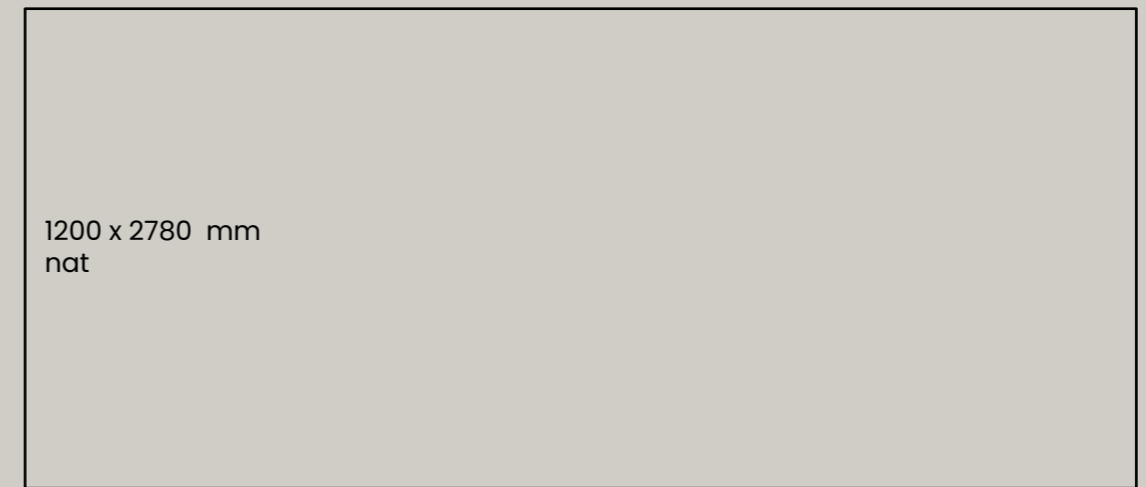

1200 x 2780 mm
nat

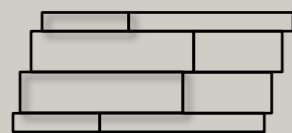

282 x 586 mm
muretto 3D mix



260 x 325 mm pol
mosaico chevron

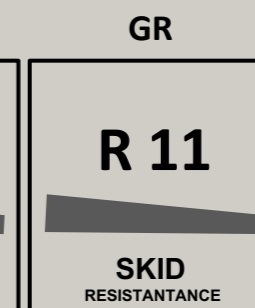
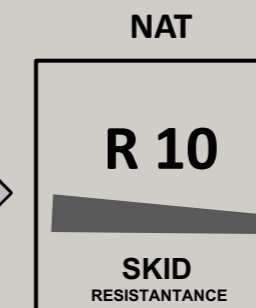
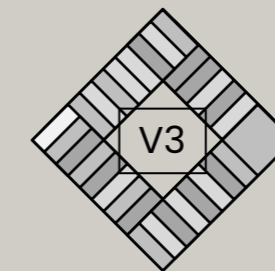



W O L F B

BEIGE



harmonic balance

HONED FINISH:

The delicate beauty of stone lapped by water. The textured surface exudes a soft balance and natural appeal, captivating in its intricacy and grace.

A gentle reminder to find beauty in the details around us.

BEIGE
800 X 800 pol

BEIGE -warm soft comfort

BEIGE
800 X 800 nat



SIZES & finishes



9 mm



natural R10 (nat)
honed (hn)
polished (pol)
grip R11 (gr)

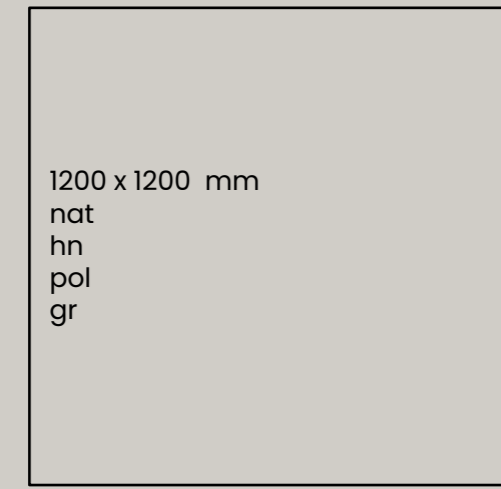

1200 x 1200 mm
nat
hn
pol
gr

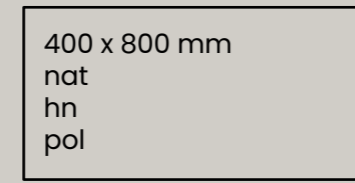

400 x 800 mm
nat
hn
pol

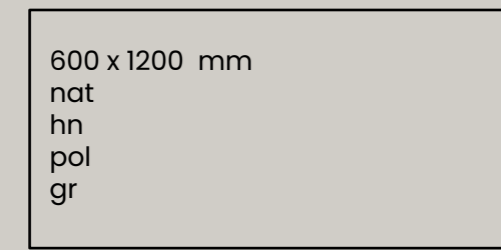

600 x 1200 mm
nat
hn
pol
gr

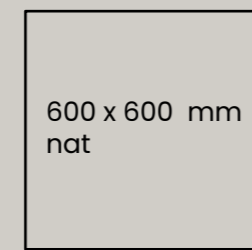

600 x 600 mm
nat

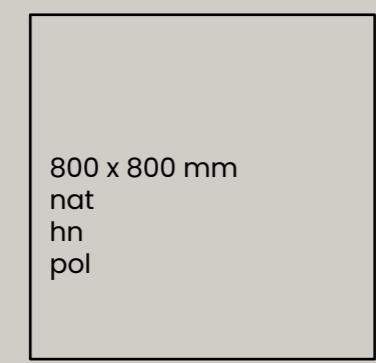

800 x 800 mm
nat
hn
pol

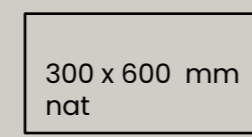

300 x 600 mm
nat



6 mm

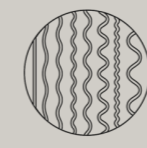

natural (nat)



1200 x 2780 mm
nat

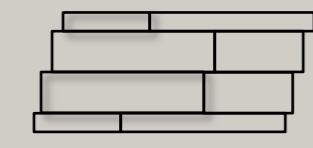

282 x 586 mm
muretto 3D mix



260 x 325 mm pol
mosaico chevron

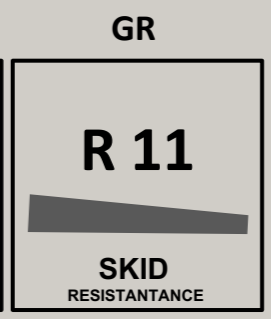
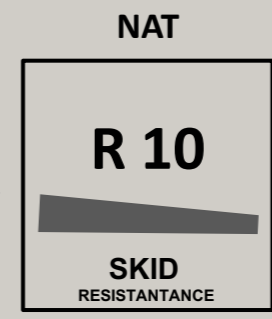
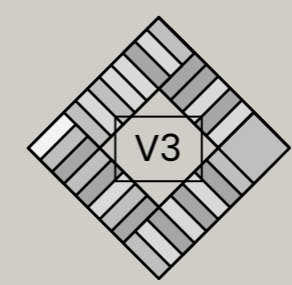



GREY

GREY

NATURAL FINISH:

The essence of transformation. A stone weathered by time. The emerging rough texture symbolizes strength and resilience, echoing the beautiful imperfections that shape us

Find beauty in every phase of our journey.



GREY
1200 x 1200 nat

GREY
1200 x 1200 nat





GREY - neutral subtle tone

GREY
floor 1200 x 1200 nat
wall 1200 x 2780 nat (6mm)

WHITE
column & planters 1200 x 2780 nat (6mm)



GREY
floor 1200 x 1200 nat
wall 1200 x 2780 nat (6mm)

WHITE
column & planters 1200 x 2780 nat (6mm)



GREY
1200 x 1200 gr

essence of matter

GREY
floor 1200 x 1200 pol

WHITE
back wall chevron pol

GRAPHITE
right wall 600 x 1200 pol





GREY
800 x 800 nat



GREY
800 x 800 nat

SIZES & finishes



9 mm

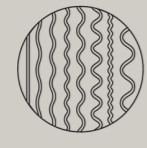

natural R10 (nat)
honed (hn)
polished (pol)
grip R11 (gr)

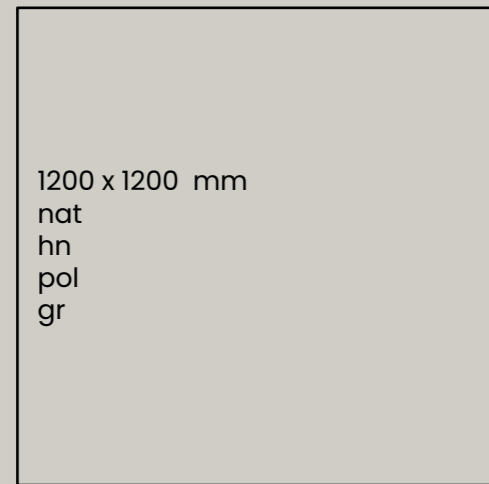

1200 x 1200 mm
nat
hn
pol
gr

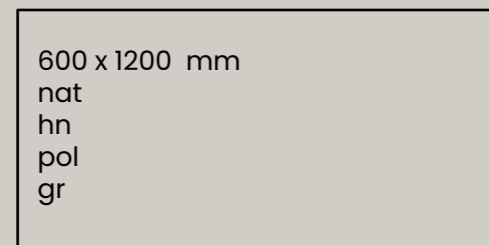

600 x 1200 mm
nat
hn
pol
gr

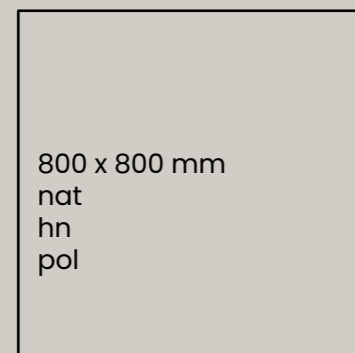

800 x 800 mm
nat
hn
pol

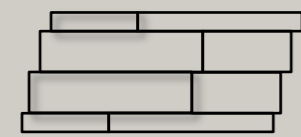

282 x 586 mm
muretto 3D mix



260 x 325 mm pol
mosaico chevron

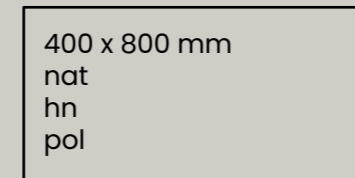

400 x 800 mm
nat
hn
pol

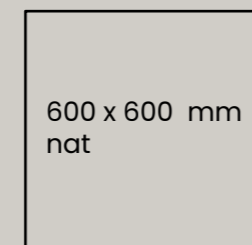

600 x 600 mm
nat

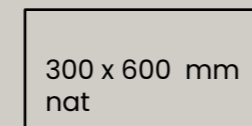

300 x 600 mm
nat



20 mm



grip R11 (gr)

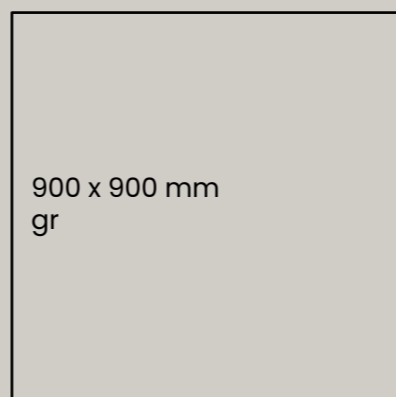

900 x 900 mm
gr



6 mm

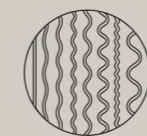

natural (nat)

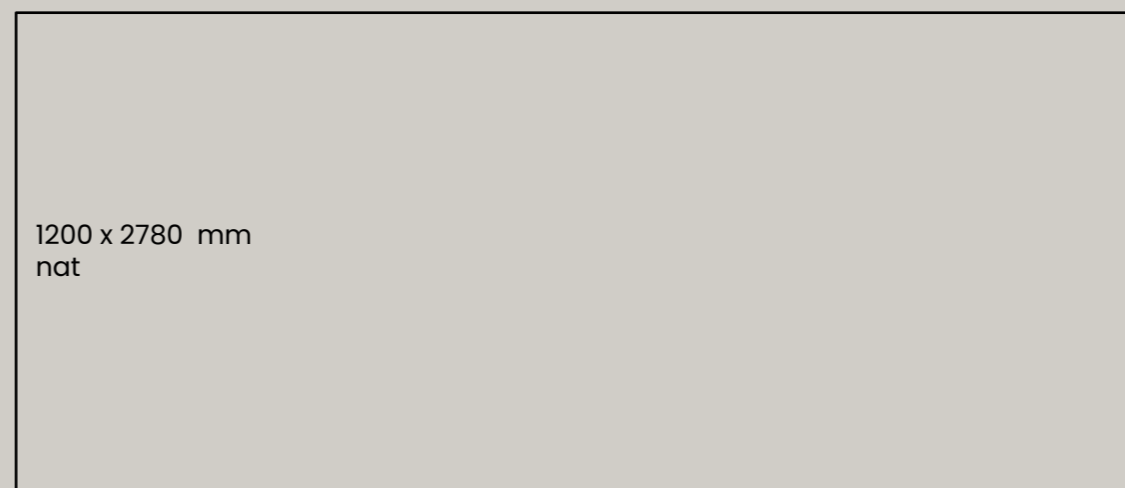

1200 x 2780 mm
nat

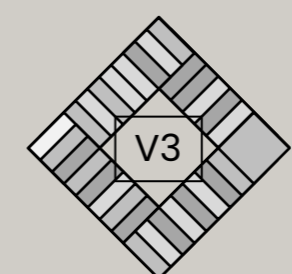

NAT	GR
R 10	R 11
SKID RESISTANCE	SKID RESISTANCE

NATURAL

NATURAL





NATURAL
1200 x 1200 nat



NATURAL
floor chevron 260 x 325 pol



NATURAL - reminiscent of waterlogged river stones

NATURAL
floor 1200 x 1200 nat

BEIGE
wall chevron 260 X 325 pol

tactile sensations

NATURAL
floor 1200 x 1200 nat

BEIGE
wall mosaico chevron 260 X 325 pol





(POLISHED FINISH:

The beauty of resilience and refinement in nature. The submerged stone, delicately polished by water, offers a reflective surface that exudes elegance and grace.

A reminder to embrace life's challenges and allow them to shape us into something truly captivating."

NATURAL
800 x 800 pol



9 mm

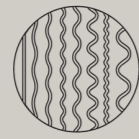

natural R10 (nat)
honed (hn)
polished (pol)
grip R11 (gr)

SIZES & finishes

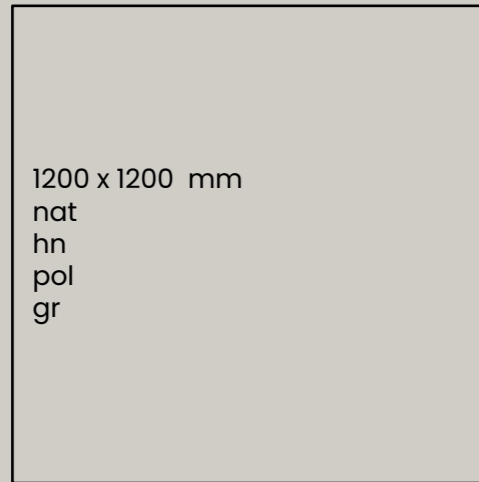

1200 x 1200 mm
nat
hn
pol
gr

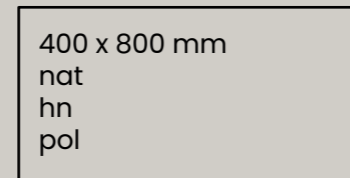

400 x 800 mm
nat
hn
pol

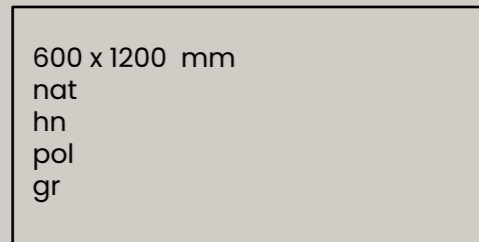

600 x 1200 mm
nat
hn
pol
gr

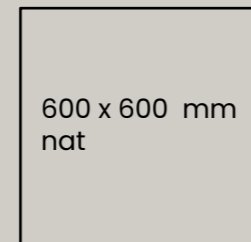

600 x 600 mm
nat

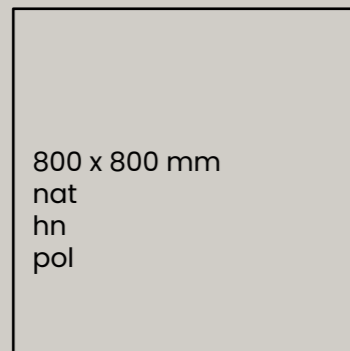

800 x 800 mm
nat
hn
pol

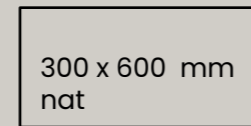

300 x 600 mm
nat



282 x 586 mm
muretto 3D mix



260 x 325 mm pol
mosaico chevron

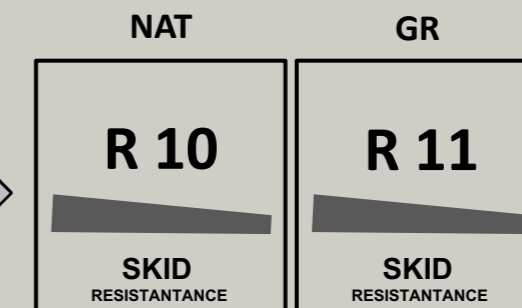
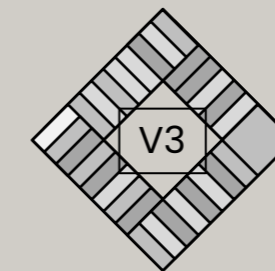

GRAPHITE

GRAPHITE





GRAPHITE - deep and mysterious

HONED FINISH:

The delicate beauty of stone lapped by water. The textured surface exudes a soft balance and natural appeal, captivating in its intricacy and grace.

A gentle reminder to find beauty in the details around us.

GRAPHITE
800 x 800 hn



GRAPHITE

floor 800 x 800 hn
side walls 400 x 800 pol
back wall muretto 3D 282 x 586 mix

ambient surfaces

The 3D Muretto, in which shiny and protruding tiles alternate with matte and recessed tiles, accentuates the perception of dynamism and materiality, recalling the contrasts generated by the action of nature.

GRAPHITE

back wall muretto 3D 282 x 586 mix



9 mm

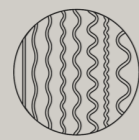

natural R10 (nat)
honed (hn)
polished (pol)
grip R11 (gr)

SIZES & finishes

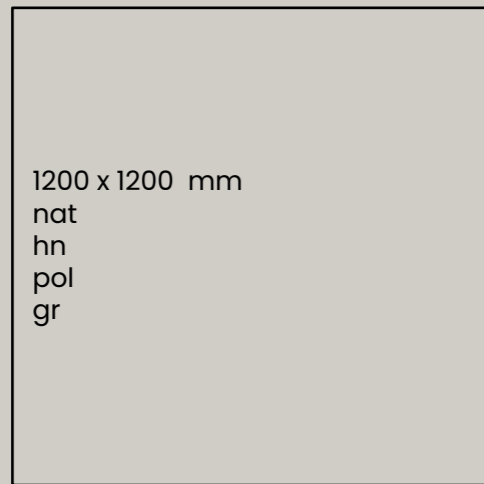

1200 x 1200 mm
nat
hn
pol
gr

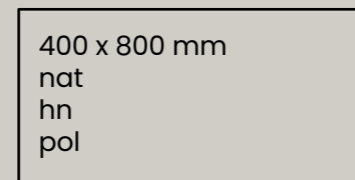

400 x 800 mm
nat
hn
pol

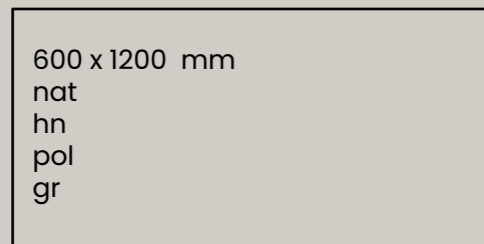

600 x 1200 mm
nat
hn
pol
gr

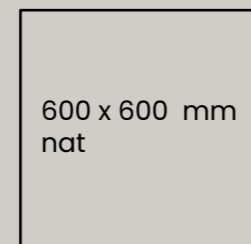

600 x 600 mm
nat



20 mm



grip R11 (gr)

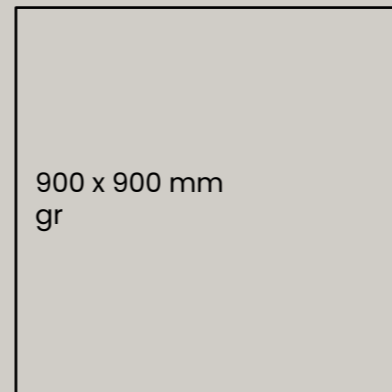

900 x 900 mm
gr

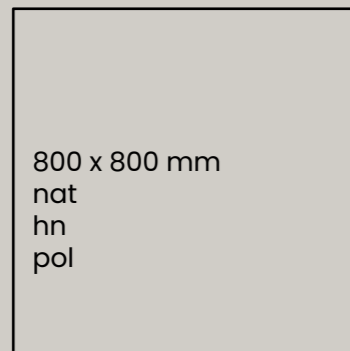

800 x 800 mm
nat
hn
pol

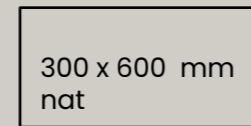

300 x 600 mm
nat

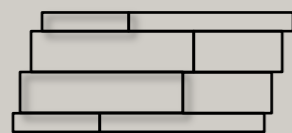

282 x 586 mm
muretto 3D mix



260 x 325 mm pol
mosaico chevron

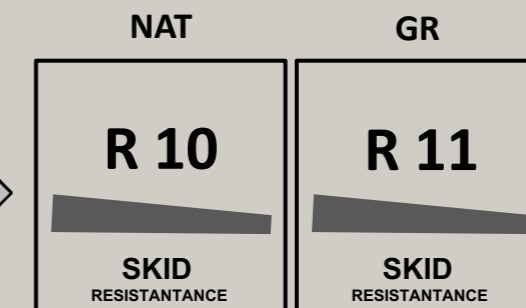
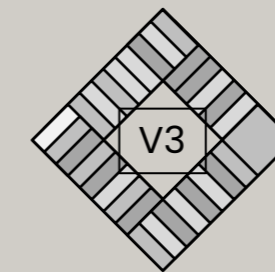

DÉCOR OPTIONS



WARM HAUT KIT
270 X 540 HN



COLD HAUT KIT
270 X 540 HN

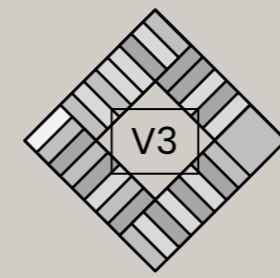
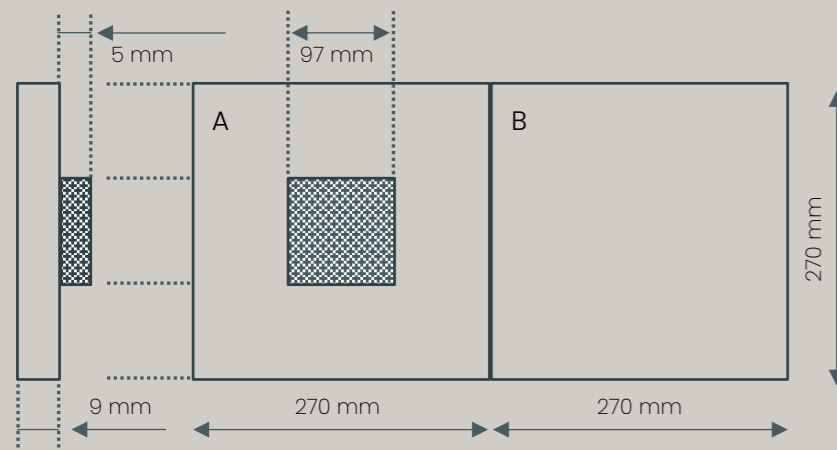

MODERATE

The Haut kit consists of two modules - A and B. A module is formed by two overlapped square pieces: the smallest one is laid with an "offset" technique that uses a patented system of grooves cut into the back of the stoneware. The resulting module is supplied already assembled. There are two colour variants: Cold with Graphite plain tile and White upper square Warm with Natural plain tile and Beige upper square. Module B is provided in the same colour as the plain tile of Module A.

GRAPHITE

floor 1200 x 1200 hn
wall cold haul kit 270 x 540 hn



DÉCOR OPTIONS

CHEVRON MOSAICS
260 X 325 mm pol



WHITE



BEIGE



GREY



NATURAL



GRAPHITE

Chevron, with its classic shape emphasised by the glossy finish, translates the refined essence of the material with the elegant fishbone application that is back in the spotlight in certain contexts, especially commercial premises.

MURRETTO 3D
282 X 586 mm mix



WHITE



BEIGE



GREY



NATURAL



GRAPHITE

The 3D Muretto, in which shiny and protruding tiles alternate with matte and recessed tiles, accentuates the perception of dynamism and materiality, recalling the contrasts generated by the action of nature.

A wide range of finishes, including the 2cm thick outdoor version



POLISHED

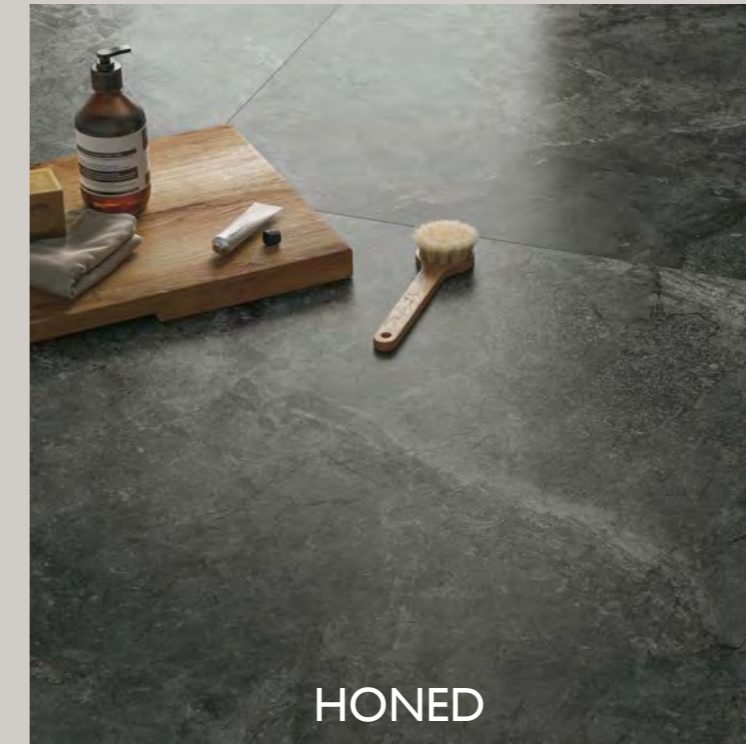

HONED



NATURAL

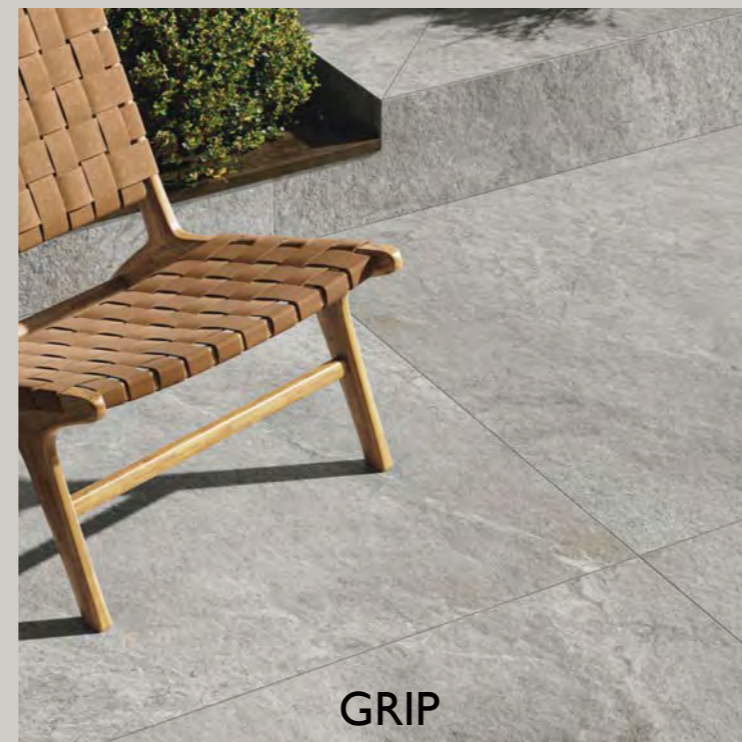

GRIP



GRIP 20MM

The moderate chromatic variation and the veining of the product is an intrinsic feature to re-create the randomness and richness of the colour shading of natural stones to which the collection is inspired. For these reasons, we recommend installing the product choosing tiles from different boxes in order to guarantee a variable and natural random effect of the finished surface. Due to these intrinsic features of the product, the colours represented in this catalogue must only be considered an example of the many possible colour shades

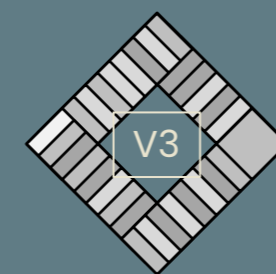

FEATURES

natural (nat)



class 5



R10



A+B



PTV \geq 36 wet



compliant



wet DCOF $>$ 0.50

honed (hn)



class 5



compliant



dry DCOF $>$ 0.42

grip (gr)



class 5



R11



compliant



wet DCOF $>$ 0.42

polished (pol)



PEI V ($>$ 12000 rev)
BEIGE & WHITE
PEI III (1500 rev) GREY
& NATURAL
PEI II (600 rev)
GRAPHITE



compliant



failed



failed

grip 20mm (gr)



class 5



R11



A+B+C



PTV \geq 36 wet



compliant













wet DCOF \geq 0.55



Gres Fine Porcellanato – EN 14411 ISO 13006 Gruppo Bla Annex G

		standard	international standards	average value
 DIMENSIONS	length & width	EN ISO 10545-2	± 0.3% max (± 1.0 mm)	complying
	thickness	EN ISO 10545-2	± 0.5% max (± 0.5 mm)	complying
	linearity	EN ISO 10545-2	± 0.3% max (± 0.8 mm)	complying
	rectangularity	EN ISO 10545-2	± 0.3% max (± 1.5 mm)	complying
	surface flatness	EN ISO 10545-2	± 0.4% max (± 1.8 mm)	complying



Gres Fine Porcellanato – EN 14411 ISO 13006 Gruppo Bla Annex G



	standard	required standards	value
 WATER ABSORPTION <small>UNI EN ISO 10545/3</small>	EN ISO 10545-3	≤ 0.5%	≤ 0.2%
 FLEX RESISTANCE <small>UNI EN ISO 10545/4</small>	EN ISO 10545-4	S ≥ 1300 N (thickness ≥ 7.5 mm) R ≥ 35N/mm ²	compliant
 COEFFICIENT OF RESTITUTION (COR) <small>UNI EN ISO 10545/5</small>	EN ISO 10545-5	recommended value ≥ 0.55/	compliant
 DEEP ABRAISION RESISTANCE <small>UNI EN ISO 10545/6</small>	EN ISO 10545-6	≤ 175 mm ³	compliant
 ABRAISION RESISTANCE <small>UNI EN ISO 10545/7</small>	EN ISO 10545-7	PEI (only for glazed tiles)	-
 COEFFICIENT OF THERMAL LINEAR EXPANSION <small>UNI EN ISO 10545/8</small>	EN ISO 10545-8	test methods available	≤ 7 · 10 ⁻⁶ · C ⁻¹
 THERMAL SHOCK RESISTANCE <small>UNI EN ISO 10545/9</small>	EN ISO 10545-9	no sample must show visible defects	compliant
 MOISTURE EXPANSION <small>UNI EN ISO 10545/10</small>	EN ISO 10545-10	test methods available	≤ 0.02% (0.2 mm/m)
 FIRE RESISTANCE <small>UNI EN ISO 13501-1</small>	EN ISO 13501-1	declare a value Class A1 or A _{1fl}	A _{1fl}
 FROST RESISTANCE <small>UNI EN ISO 10545/12</small>	EN ISO 10545-12	resistant	compliant

“Ceramics of Italy”

100%
MADE IN ITALY

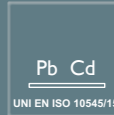
Gres Fine Porcellanato – EN 14411 ISO 13006 Gruppo Bla Annex G

	standard		required standards	value
				nat
 CHEMICAL RESISTANCE <small>UNI EN ISO 10545/13</small>	EN ISO 10545-13	resistance to household chemicals and swimming pool salts	minimum Class B (GB for glazed tiles) minimum Class B (UB for unglazed tiles)	A
		resistance to low concentrations of acids and alkalis	declare a class test methods available	LA (not valid for polished surface)
		resistance to high concentrations of acids and alkalis	declare a class test methods available	HA (not valid for polished & honed surfaces)
 STAIN RESISTANCE <small>UNI EN ISO 10545/14</small>	EN ISO 10545-14		UGL declare a value GL ≥ 3	Class 5 resistant
 LEAD & CADMIUM DISCHARGE <small>UNI EN ISO 10545/15</small>	EN ISO 1545-15		declared value for GL tiles	than instrument limit

	standard	required standards	value			
			nat	hn	pol	gr
 ASSESSMENT OF SLIP RESISTANCE	DIN EN 16165:2021 ANNEX B (previously DIN 51130)	declare a value (R)	R10	-	-	R11
	DIN EN 16165:2021 ANNEX A (previously DIN 51097)	declare a value (A+B+C)	A+B	-	-	A+B+C
	BS EN 16165:2021 ANNEX C (previously BS7976-2-2002)	declare a value	≥ 36 wet nat	-	-	≥ 36 wet nat
	 MEASUREMENT OF DYNAMIC COEFFICIENT OF FRICTION	B.C.R.A. Rep. CEC/81	bagnato > 0.40	compliant	compliant	failed
DCOF ANSI A326.3 (BOT3000) test method		> 0.42 wet	> 0.50 wet	> 0.42 dry	failed	> 0.55 wet

NOTE

The polished (pol) finish does not meet the minimum coefficient of friction, according to the most relevant national standards for antislip resistance (as per example: ANSI 137.1-2012 / BOT3000; b.C.R.A. REP. CEC/81; DIN 51130; DIN 51097).

slate effect
RI COLLECTION



STONEGRES

Stonegres Limited
20-22 Wenlock Road
London
N1 7GU
tel: 020 8943 3154

info@stonegres.co.uk | www.stonegres.co.uk