

*Complete the Look*

SEAMLESS *spaces*



STONEGRES

Enamel water-based polyurethane resin which, thanks to its versatility, enables a complete look effect.

## RESINA ARREDO

Decorative finish for indoor surfaces and furnishings. One of the most electrifying innovations, a multi-faceted product to be discovered, a total look for tiled surfaces, furniture, and furnishings; it renews and redesigns spaces with monotone solutions in lively, saturated colours. Super-opaque, available in both a Satin and Glossy version, it allows both colour consistency for open, minimalist spaces, and contrasting colours for cheerful, lively spaces.

## BATTISPAZIO

Skirting boards in hand-crafted and painted wood with anti-humidity treatment, carefully and elegantly designed, available in 3 different heights. Suitable for commercial spaces and all areas of the home.

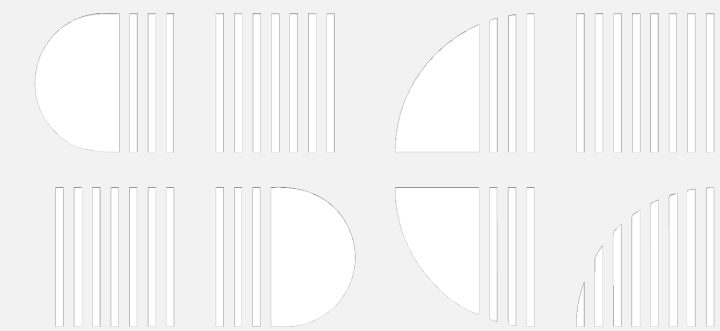
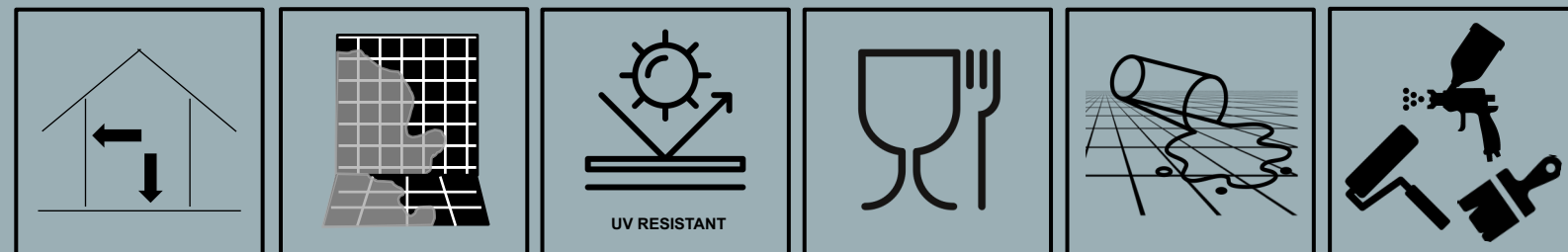

STONEGRES



*complete the look*

ResinaArredo  
NCS 2010-B90G

ResinaArredo  
NCS3060-B40G

# RESINAARREDO

Dense, deep, soft-to-the-touch backgrounds to cover any surface of the home: floors, walls, skirtings, fixtures, doors, furniture.

A furnishing solution to renew and transform the entire home with colour, without the need for costly masonry works.

A material giving free rein to the imagination and the possibility to develop original, entirely unique and personalised living solutions where colour becomes the absolute protagonist of the space. ResinaArredo is a liquid resin that is easy to apply with a roller, brush or airless sprayer and is available in two versions: Gloss and Satin; suitable for any type of substrate, it guarantees consistent and compact coverage with excellent resistance to abrasion and washing.

Available in the 27 prestigious nuances of the palette by Rinaldo Rinaldi for Spaziocontinuo®, and on request all colours in the NCS and RAL colour charts.





*complete the look*



ResinaArredo  
73

Decorative finish for indoor surfaces and furnishings.

One of the most electrifying innovations, a multi-faceted product all to be discovered, a total look for tiled surfaces, furniture, and furnishings; it renews and redesigns spaces with monotone solutions in lively, saturated colours.

Super-opaque, available in both a Satin and Glossy version, it allows both colour consistency for open, minimalist spaces, and contrasting colours for cheerful, lively spaces.





complete the look

ResinaArredo  
35



ResinaArredo  
63



ResinaArredo  
25





complete the look

RESINA ARREDO



RESINAARREDO

■ 25

the colour palette

La tavolozza di RINALDO RINALDI

SPAZIOCONTINUO LE RESINE DI LITOKOL

11	21	31				
12	22	32				
13	23	33	41	51	61	71
14	24	34	42	52	62	72
15	25	35	43	53	63	73

*complete the look*



## BATTISPAZIO

Skirting boards in hand-crafted and painted wood with anti-humidity treatment, carefully and elegantly designed, available in 3 different heights. Suitable for commercial spaces and all areas of the home.

BattiSpazio is an essential decorative element of the interior design solution, and plays an important role in determining its style and volumes. Protecting the walls is but one function of a skirting board, which is also key in determining the overall perception of the space and its visual design according to one's own personal style.

BattiSpazio is available in three sizes, Small, Medium and Large, and allows utmost personalisation of spaces.

BattiSpazio is the best choice for those looking for something different, compatible with the light and essential lines of a more modern style. Colour and height are the variables that will determine the desired effect, without forgetting that a well-selected architectural element is always the best weapon to distract our gaze from small defects. Available in the 27 prestigious nuances of the palette by Rinaldo Rinaldi for Spaziocontinuo®, and on request all colours in the NCS and RAL colour charts.

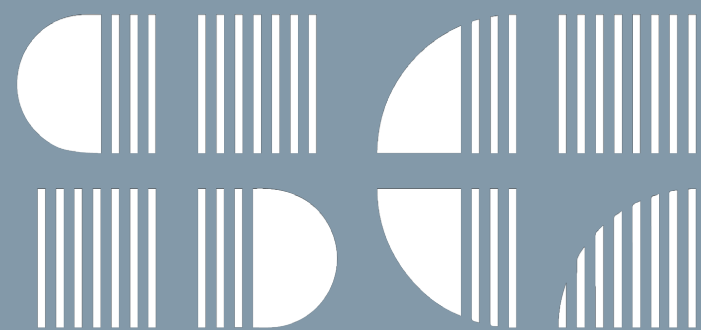

STONEGRES



*complete the look*

SPAZIORESINA

■ wall: 22 + 21

BATTISPAZIO

■ skirting: NCS S 9000N

Although choices will ultimately be determined by personal style and preferences, the main selection criteria for skirting boards in interior design should be noted:

❖ Matching BattiSpazio with the floor. This first type is a great classic. The strip of material along the bottom of the walls is a natural continuation of the floor; a skirting board in the same colour as the floor offers stylistic consistency, making the room appear larger and more orderly. Essential and elegant.

❖ Matching BattiSpazio with the walls. This solution, undoubtedly linked to modern and contemporary styles, is experiencing a strong rise in popularity; the design-motivated choice to make the skirting board match the walls makes it invisible, perfect for essential and minimalist interiors. The matching colour can also help elongate the walls in the case of low ceilings.

❖ Matching BattiSpazio with the doors. This is another very popular and traditional solution, because it creates colour continuity with the fixtures. Matching BattiSpazio with the doors or window profiles creates a continuous design along the entire wall, outlining the perimeter for a highly characteristic effect. In small environments, for example, it is recommended to opt for solutions that fluidify the perception of the space. In this case, intent marries well with aesthetic reason: the skirting board frames the door and recalls the decorative motif.

❖ Non-matching, contrasting. Those looking for a more modern, non-conventional, and original approach can opt for this solution. The room certainly won't go unnoticed. To highlight a furniture element or the colour of the walls, or perhaps play with different shades to emphasise the style of the room, a contrast might be the best option. What does this mean in terms of perception? Our gaze is distracted from the real size of the room and is captured by the style instead

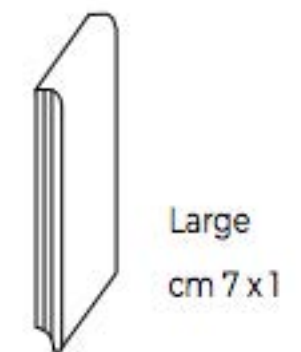
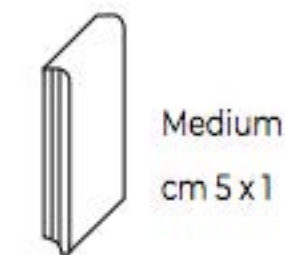
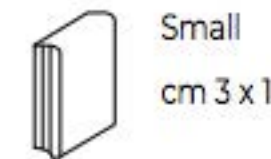



*complete the look*





complete the look

BATTISPAZIO



SPAZIORESINA

wall: 22 + 21

BATTISPAZIO

skirting: NCS S 9000N

the colour palette

La tavolozza di RINALDO RINALDI

SPAZIOCONTINUO LE RESINE DI LITOKOL

11	21	31				
12	22	32				
13	23	33	41	51	61	71
14	24	34	42	52	62	72
15	25	35	43	53	63	73



## HYDROLUX EVO

Two-component water-based polyurethane clear protective finish that provides resistance to wear, yellowing, stains, intermittent contact with water and humidity.

The three available finishes, matt, gloss and satin, each define a very precise level of light reflection: this means that colour and texture being equal, different results will be obtained depending on the selected finish. Light, whether natural or artificial, strikes the objects, walls, furniture in the home and these can either reflect or diffuse it. This action depends on the properties of the finish. The three types of finishes influence the colour in different ways, and therefore the aesthetic result.

Resistance to the most common staining agents.

After a contact time of 24 hours, no halos or stains are observed:

Water - Bleach - Vinegar - Neutral detergents - Citric acid 10% - Ketchup - Oxygenated water 10 vol. - Mascara - Denatured alcohol - Olive oil - Ammonia - Water markers - Anti-limescale - Coffee - Red wine.

After 24 hours, light and scarcely visible halos appear: Permanent markers - Hair dye





## HYDROLUX EVO

**Matt Finish:** the light is reflected in a diffused manner with respect to the ray that hits the surface, thus making the colours appear lighter and more subdued.

Ideal for rooms dedicated to relaxation such as bedrooms and living rooms. The matt look “absorbs” the light, hides any imperfections, and gives the space a sense of sobriety and intimacy.

**Satin Finish:** a semi-matt or semi-gloss finish obtained by searching for the perfect balance between light reflected in a specular and diffused way. Ideal for all rooms in the home, the satin effect offers the surface a balanced and regular appearance. The soft aspect of the surface is perceived in the same way, both visually and to the touch.

**Gloss Finish:** the light reflects in a specular manner with respect to the ray that hits the surface, thus making the nuances appear brighter and more lively. It is therefore particularly suited for SpazioLamina#Crudo and SpazioLamina#Perlato continuous surfaces to enhance the metallic and pearlescent effects.





# PROTETTIVO NATURALE EVO

Single component water-based protective finish with natural effect.

Protettivo Naturale EVO is the protective finish that provides resistance to wear, yellowing, and stains.

Excellent resistance to scratches, highlights the effects of the underlying textures. While satin, gloss or matt finishes can enrich surfaces with new effects and therefore broaden the possibilities to personalise the space, for purists of "natural" matter, Spaziocontinuo proposes this clear solution specifically designed for the SpazioChiaroscuro, SpazioMateria, and SpazioMetallo decorative wall systems.

Its total transparency allows surfaces to be protected without influencing their appearance in any way.

This makes it possible to appreciate all the naturalness of the mélange of SpazioChiaroscuro colours, or else the different effects of various lighting on SpazioMetallo pearlescent surfaces, and even SpazioMateria delicately rippled surfaces. In wet areas or if the client desires a matt, gloss, or satin effect, this is possible by applying a Hydrolux EVO polyurethane clear protective finish.

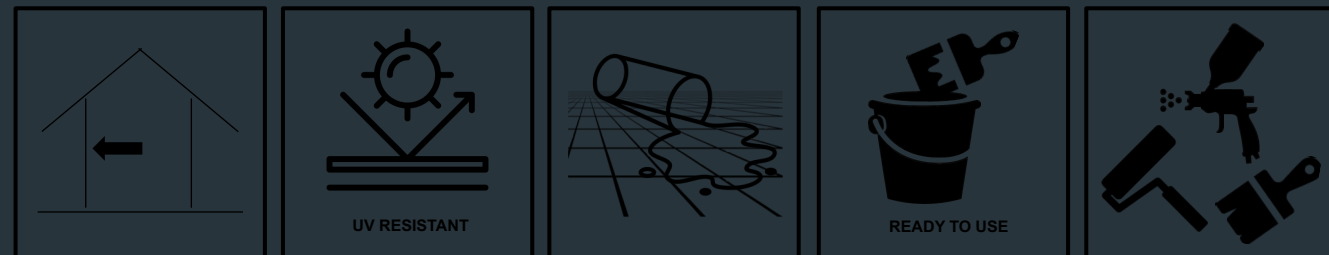



*Complete the Look*

**SEAMLESS** *spaces*

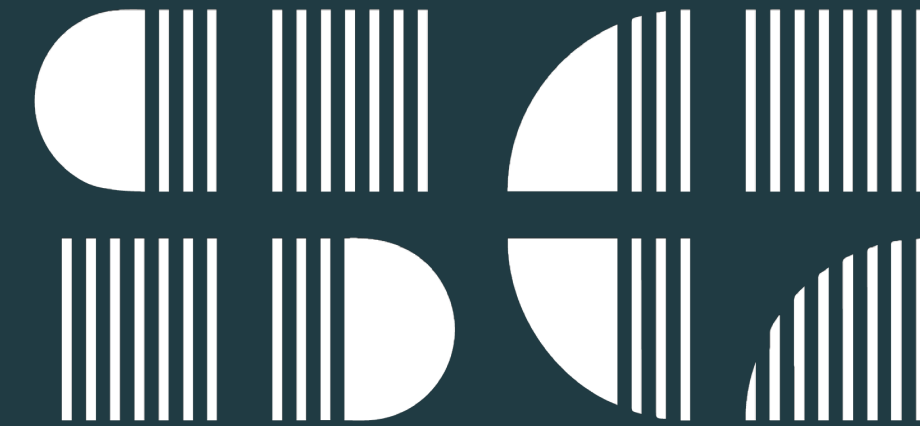

**STONEGRES**

Stonegres Limited

Registered Office  
20-22 Wenlock Road  
London  
N1 7GU

Private Studio – appointment only  
130A Acre Road  
Kingston Upon Thames  
KT2 6ED

tel: 020 8943 3154  
info@stonegres.co.uk | www.stonegres.co.uk

**Notes:**

The reliability of the colours shown and photographic images is very high, however these must nonetheless be considered indicative as they are influenced by the type of lighting and printing.

The spatula effect and chiaroscuro textures of the coverings are characterised by slight irregularities and colour movements typical of manual processing: these represent the most exclusive aesthetic features of continuous floors, making each installation unique.